

**TCS DCC decoders provide the ultimate in control.**



This decoder is in # \_\_\_\_\_  
\_\_\_\_\_

# TH141

## Four Function Decoder

1.3 amp continuous, 2.0 amp peak motor drive  
**plus four 100 mA function outputs**

**Dither creates the ultimate in slow speed control.  
Quiet Drive creates smooth quiet engine performance.  
Factory Reset the fast way back to original settings.  
Goof Proof warranty no questions asked.**

**Reversing Headlights, Rule 17 dimming, Opposite Dim, Random Flicker, Blinking  
Ditch Lights, Mars Light, Gyra Light, Rotary Beacon, Single Pulse Strobe,  
Double Pulse Strobe and Flashing light.**

**Brake on DC** feature allows stopping and starting when a DC section is active,  
all with your programmed acceleration, deceleration and desired lighting.

**Autodetect senses DCC or DC** power and operates at peak performance on either.

**Button Control** ( Function Remapping ) lets most buttons control the lights.

**All Program Modes are supported** allowing use with any controller.

**14 or 28 / 128 Speed Step Control** operating at 256 speed steps

**Basic and Advanced Consisting** for use with any controller.

**User Loadable Speed Tables** for custom speed curves.

**OPS Mode Programming** allows on track programming

**Standard 2 Digit or Extended 4 Digit Addressing**

9 pin Wiring Harness

Compatible with NMRA DCC standards.

Made by **TCS** in the USA.

**Contact TCS at:** P.O. Box 341, 845 Blooming Glen Rd., Blooming Glen, PA 18911  
Phone **215-453-9145** Fax **215-257-0735** Email **tcs@ot.com** Web **www.tcsdcc.com**

# INSTALLATION INSTRUCTIONS

See the Programming Supplement ( Insert ) for Installation Information.

## BASIC CONFIGURATION

Make one choice from each row from "A" through "E" and total them on line 1.					Record
A	Normal Direction in Forward = 0	OR	Reverse Direction in Forward = 1		
B	14 Speed Steps = 0	OR	28 / 128 Speed steps = 2		
C	Analog ( DC ) operation disabled = 0	OR	Analog ( DC ) operation enabled = 4		
D	Loadable Speed Table Inactive = 0	OR	Loadable Speed Table Active = 16		
E	2 Digit Addressing = 0	OR	4 Digit Addressing = 32		
1	Basic Configuration of the Decoder		total "A" thru "E"	CV 29	6

## ADDRESSING

Primary 2 Digit Address					Record
2	Primary Loco Address	use when "E" = 0	CV 1	3	
Advanced 4 Digit Address					Record
3	First two digits of Extended Address	use when "E" = 32	CV 18	0	
	Last two digits of Extended Address	use when "E" = 32	CV 17	0	

Consist Address If this is greater than 0, you can't alter the regular address.					Record
4	2 Digit Address when added to a consist ( Multiple units ).		CV 19	0	

NOTE: If you want to maintain some or all engine lighting when in consist, see table 17.  
 NOTE 2: Add 128 to reverse the engine direction when in consist. **Some systems only!**

## MOTOR CONTROL

Start Volts It is superceded by Dither. For most conditions, leave this "0".					Record
5	Start Volts	1 volt = roughly 18	use if "D" = 0	CV 2	0

Speed Graph Using "0" ( the default value ) produces straight line acceleration.					Record
6	Top Volts	1 volt = roughly 18	use if "D" = 0	CV 5	0
	Mid Volts	1 volt = roughly 18	use if "D" = 0	CV 6	0

NOTE: Adjust these to make engines run alike. This is useful in multiple unit operation.

Momentum creates the effect of engines pulling and stopping heavy loads.					Record
7	Acceleration	Adds time to each speed step. Practical range is 0-25		CV 3	0
	Deceleration	Adds time to each speed step. Practical range is 0-25		CV 4	0

8	Loadable Speed Tables										Use if "D" = 16
	CV 67	2	CV 74	30	CV 81	72	CV 88	135			
	CV 68	5	CV 75	35	CV 82	79	CV 89	147			
	CV 69	7	CV 76	40	CV 83	84	CV 90	161			
	CV 70	12	CV 77	47	CV 84	93	CV 91	177			
	CV 71	16	CV 78	51	CV 85	100	CV 92	196			
	CV 72	21	CV 79	58	CV 86	112	CV 93	219			
	CV 73	26	CV 80	65	CV 87	121	CV 94	255			

NOTE: Shaded CVs are the ones used for 14 speed steps ( when "B" = 0 ).

<b>Kick Start</b> It is superceded by <b>Dither</b> . A value of "0" in CV 65 nullifies Kick Start.				Record	
<b>9</b>	<b>Burst Duration</b>	Higher values increase duration. 60 = 1 sec.	<b>CV 58</b>	<b>50</b>	
	<b>Burst Voltage</b>	Higher values increase voltage. 18 = roughly 1 volt	<b>CV 65</b>	<b>0</b>	

**Dither provides the ultimate in slow speed control.** Engines will run slower than one half MPH. **NOTE: Both CV 56 and CV 57 must be greater than 0.**

				Record	
<b>10</b>	<b>Dither Frequency</b>	The frequency range is 1 ( high ) to 10 ( low )	<b>CV 56</b>	<b>6</b>	
	<b>Dither Voltage</b>	The practical range is 5 ( low ) to 50 ( high )	<b>CV 57</b>	<b>15</b>	

**NOTE:** If the flywheel isn't moving with the throttle at 1% or 2%, increase CV 57 by 5 until you have some very slow movement of the flywheel. If you want to change the motor speed, increase or decrease CV 56 by 1 until it is running as desired.

## LIGHTING CONTROL

Lighting				Timing + Effect = Total		
<b>11</b>	White Wire	<b>CV 49</b>	<b>0</b>		+	=
	Yellow Wire	<b>CV 50</b>	<b>16</b>		+	=
	Green Wire	<b>CV 51</b>	<b>32</b>		+	=
	Purple Wire	<b>CV 52</b>	<b>32</b>		+	=

Choice of lighting effects.	
Constant Bright Light = 0	
Random Flicker ( fire box ) = 1	
Mars Light = 2	
Flashing Light = 3	
Single Pulse Strobe = 4	
Double Pulse Strobe = 5	
Rotary Beacon = 6	
Gyra Light = 7	
Rule 17 ( dimmable light ) = 8	
Ditch Light phase A = 10	
Ditch Light phase B = 11	
Constant Dim light ( 50% power ) = 12	

Choose when you want the light On ( timing ).	
Light is On when running Forward only = 0	
Light is On when running in Reverse only = 16	
Light is On when running in Both directions = 32	

**NOTE:** Add the value you choose for the light timing to the value you choose for the lighting effect to get the value you need for the CV you are programming.

<b>CHOICES:</b>	Dims when loco is stopped = 16	Opposite headlight is on dimmed = 32	Record Your Total
<b>12</b>	<b>Headlight Dimming Parameters</b>	<b>CV 61</b>	<b>0</b>

**NOTE:** This is not used unless you have an 8 in the effect column of table 11.

1 second = about 12		Record Your Choice
<b>13</b>	<b>Ditch Light Blink Holdover Time</b>	<b>CV 63</b> <b>64</b>

**NOTE:** This is not used unless you have a 10 and 11 in the effect column of table 11.

**Gyra or Mars Light Modification.** You can use only the Gyra light or Mars light at a particular time. CV 59 controls total cycle time. Lower values equal a shorter cycle. CV 60 controls time at low power. Lower values equal less time at low power. The default values are for a Gyra light. Set up for a Mars light by trying CV 59 = 46 & CV 60 = 12.

		Gyra Light	Mars Light
		Record	Record
<b>14</b>	<b>Oscillating Light Modulation</b>	<b>CV 59</b>	<b>46</b>
	<b>Oscillating Light Latency</b>	<b>CV 60</b>	<b>54</b>

**NOTE:** This is not used unless you have a 2 or 7 in the effect column of table 11.

**Button Control** Circle the value under the button number you want to control each wire. One button can control multiple wires. One wire can be operated by multiple buttons.

15	Button Number	8	7	6	5	4	3	2	1	R-0-F	Total for each Row		
	White Wire			128	64	32	16	8	4	2	1	CV 33	1
	Yellow Wire			128	64	32	16	8	4	2	1	CV 34	2
	Green Wire			128	64	32	16	8	4	2	1	CV 35	4
		8	4									CV 37	4
	Purple Wire			128	64	32	16	8	4	2	1	CV 36	8
		8	4									CV 38	8
Ditch Lights Flash on button 2 or 5					5			2	Choose a single ( on / off ) button for both ditch light wires.				
Rule 17 dims when button 4 is pressed						4							

**NOTE:** If you are using Ditch Lights, do not use buttons 2 or 5 for any wires because these buttons control the ditch light flash. If you are using light dimming, do not use button 4 for any wire because it controls light dimming. You may use buttons 2, 4 & 5 as you wish if there is no conflict with ditch lights or headlight dimming.

CHOICES:	White and Yellow Wire = 1	Green Wire = 2	Purple Wire = 4	Record Your Total	
16	Wires you want to use with Analog ( DC ) Power			CV 13	255

**NOTE:** If you are powering one or more of these wires with the red or black wires ( AC ), do not have that wire active with DC power because the voltage will be higher.

CHOICES:	Green Wire = 1	Purple Wire = 2	Record Your Total	
17	Wires you want active when engine is part of a Consist		CV 21	0
CHOICES:	White Wire = 1	Yellow Wire = 2	Record Your Total	
17	Headlight wires you want active when engine is in a Consist		CV 22	0

**NOTE:** You can program a pair of engines so that when in consist, only some lights of the front engine light and only some lights of the rear engine light.

## CONVENIENCE

Factory Reset allows you to reset all of the CVs with a shaded default value back to there factory set value. To start the process, enter a value of 2 in either CV 30 or CV 8.

Then turn off the power and then restart. The reset is now complete.

		Record Your Choice	
18	Factory Reset	CV 30	0

Identification Numbers		Record Your Choice	
19	TCS Decoder Version Identification	CV 7	
	TCS Manufacturer Identification Number	CV 8	153
	User Identification Provided for User	CV 105	0
	User Identification Provided for User	CV 106	0

## WARRANTY

This decoder is covered by a one year goof proof, no questions asked replacement warranty. Send decoders directly to TCS. Please include your phone number, Email address, and street address when returning any items.

## WARNING

The interior of this product contains chemicals known to the state of California to cause cancer, birth defects or other reproductive harm.

# TH141

## Programming Supplement Page 1

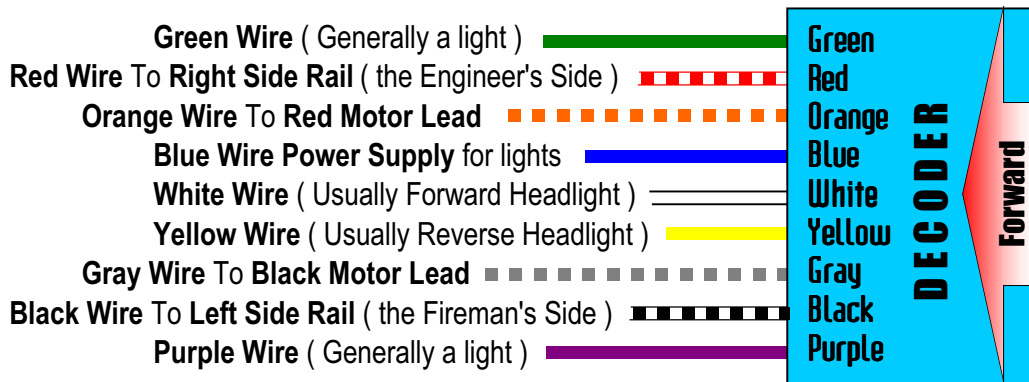

If the engine runs backwards, reverse the red and black motor leads. If the engine and lights work backwards, do one of the following: ( A ) Turn the board 180 degrees from its present position. ( B ) Look at the value you have for "A" in table 1 ( CV 29 ). If you have a 0 for "A", add 1 to the total you have for CV 29. If you have a 1 for "A", subtract 1 from the total you have for CV 29. This will reverse the phase as it was wired.

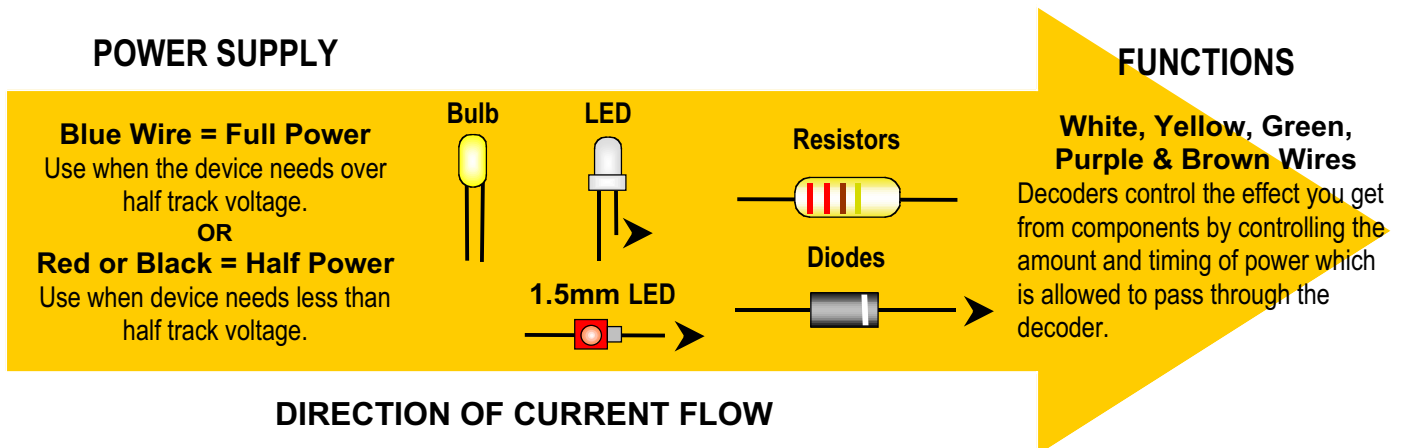

**Light Bulbs** can eat up your systems power supply. Use the smallest mA rating you can to achieve your desired effect. They are non directional so either wire may be connected to the power supply.

**LEDs** provide a lot of light per mA. The downside is the light is mostly directed forward ( great for headlights, not good for interior lighting ) and they react so fast that they lose softness modifying some lighting effects. Connect the long lead to the power supply. Connecting backward won't cause damage but it won't light.

**Resistors** are non directional. Use the resistor chart as a guide for the proper resistance value.

**Diodes** are directional. Their purpose is to allow current to flow in one direction only. Note the flow shown above. They may be required when using a solenoid, relay or capacitor.

# TH141

## Programming Supplement Page 2

### Explanation of Available Power Supplies

Power to supply the White, Yellow, Green, Purple and Brown wires is available from three wires. The Blue wire provides Full Power DC. If you use the Black or the Red wire to power a feature, you have Half Power DC which will be about half the voltage of the Blue wire. When you use Red to Black you have Full Power AC ( track voltage ).

Since track voltages for HO vary from 12 v to 16+ v depending on your DCC system, we are forced to relate everything to track voltage rather than using specific voltages.

When using bulbs rated less than the track voltage, you must use a resistor in series with the bulb.

Light Type and Power Source		Resistor Values in Ohms			
Quantity and Type of Light		Power Wire	12 V. Track	14 V. Track	16 V. Track
12 V	( 1 ) 30ma Bulb	Blue	0 to 100	47 to 150	100 to 220
	( 2 ) 30ma Bulbs in Parallel	Blue	0 to 68	33 to 82	56 to 100
	( 3 ) 30ma Bulbs in Parallel	Blue	0 to 68	10 to 68	22 to 68
1.5 Volt	( 1 ) 30ma Bulb	Blue	270 to 390	330 to 390	470 to 560
	( 2 ) 30ma Bulbs in Series	Blue	220 to 330	270 to 330	470 to 560
	( 4 ) 30ma Bulbs in Series	Blue	180 to 270	270 to 390	330 to 470
	( 1 ) 30ma Bulb	Red <i>or</i> Black	180 to 270	220 to 330	270 to 390
1.5 Volt	( 2 ) 30ma Bulbs in Series	Red <i>or</i> Black	100 to 180	150 to 220	220 to 330
	( 4 ) 30ma Bulbs in Series	Red <i>or</i> Black	10 to 100	47 to 150	82 to 180
	( 1 ) White LED	Red <i>or</i> Black	180 to 1200	220 to 1500	270 to 1800
LED	( 2 ) White LEDs in Series	Red <i>or</i> Black	82 to 680	150 to 820	180 to 1200
	( 1 ) Color LED	Red <i>or</i> Black	220 to 1200	270 to 1800	330 to 2200
	( 2 ) Color LEDs in Series	Red <i>or</i> Black	150 to 1000	220 to 1500	270 to 1800
	( 3 ) Color LEDs in Series	Red <i>or</i> Black	0 to 560	100 to 1000	220 to 1200
	( 4 ) Color LEDs in Series	Red <i>or</i> Black		82 to 820	180 to 1000
	<b>Constant Lighting Wired Across Rails</b>			<b>12 V. Track</b>	<b>14 V. Track</b>
12 V	( 1 ) 30ma Bulb	Red <i>to</i> Black	0 to 100	82 to 150	150 to 330
	( 2 ) 30ma Bulbs in Parallel	Red <i>to</i> Black	0 to 68	47 to 82	82 to 150
	( 3 ) 30ma Bulbs in Parallel	Red <i>to</i> Black	0 to 33	33 to 56	56 to 100
	( 4 ) 30ma Bulbs in Parallel	Red <i>to</i> Black	0 to 22	22 to 47	39 to 82
LED	( 1 ) White LED	Red <i>to</i> Black	180 to 1200	270 to 1500	330 to 1800
	( 2 ) White LEDs in Series	Red <i>to</i> Black	100 to 680	180 to 1000	220 to 1200
	( 2 ) Color LEDs in Series	Red <i>to</i> Black	180 to 1000	220 to 1200	270 to 1500

NOTE: If you are powering features with the red or black wires, make sure to make those features inactive on DC power because the voltage will be higher. See table 16.

Contact TCS at  
P.O. Box 341  
845 Blooming Glen Rd.  
Blooming Glen, PA 18911



Phone 215-453-9145  
Fax 215-257-0735  
Email tcs@ot.com  
Web www.tcsdcc.com